

SALVACARGAS S-200



Características de diseño

Modelo: S-200	Presión de diseño: 6 kg/cm ²
Longitud total: 770 mm	Conexión máxima: Ø 225 (DN200)
Diametro: Ø 415 mm	Caudal máximo: 200 m ³ /h

Materiales

Cuerpo: PRFV laminado	Ranuras en brazos: 0.2 / 0.5 mm
Union de cuerpos: PRFV laminado	Entrada/Salida: Bridas en PRFV
Mirilla: Metacrilato	Vaciado: Rosca de 1 ½" en PRFV

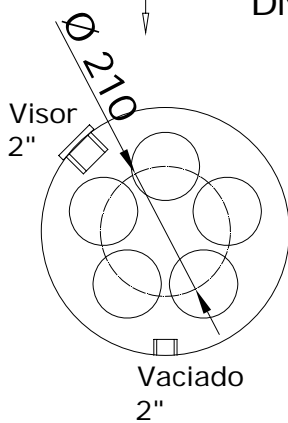
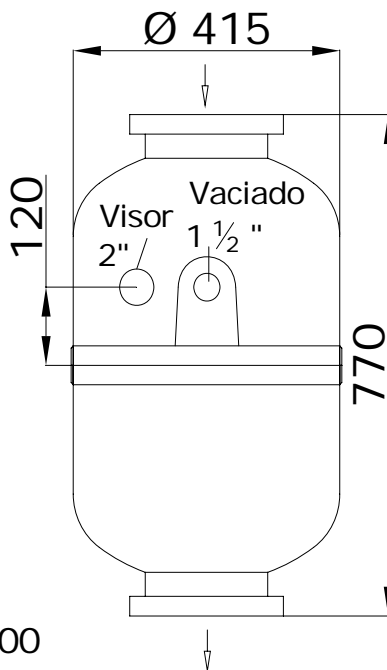
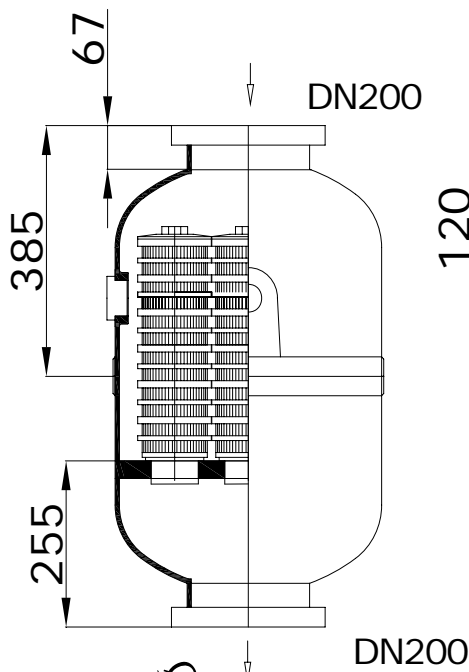

Bridas en PRFV



Mirilla en metacrilato

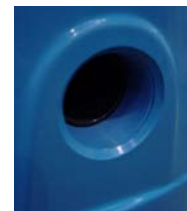

Vaciado en PRFV Rosca GAS

